

EUROTEK

Eurotek Group



Company Profile

www.eurotek.eu.com

info@eurotek.eu.com

FROM CONCEPT TO CASTING

EUROTEK

EUROTEK

Eurotek Group

EUROTEK

Eurotek Foundry Products Ltd

Eurotek Engineering Services

Eurotek - Polska





UK Operation



FROM CONCEPT TO CASTING

Product Range - Binders

- **Furan Resin – *Permacol, Permaset,***
- **Alkaline Phenolic – *Permabind***
 - **Cold-set**
 - **Gas Cured (Methyl formate)**
- **Urethane binders - *Permacure***
 - **Cold-box and Air set**
- **Sodium Silicate - *Permasil***
 - **Air-set and CO₂ cured**
- **Hot-Box - *Permabox***

EUROTEK

Permacol



PERMACOL offers high tensile strengths and low binder levels for cores & moulds both boxed & boxless

FROM CONCEPT TO CASTING

EUROTEK

Permacure Airset

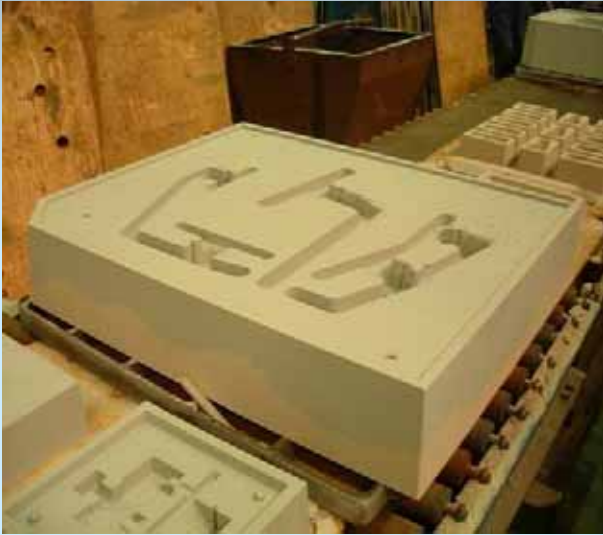

High Tensile strengths
offers low binder additions

Excellent Bench life
to Strip time ratio
gives high volume
moulding capability



Use of fine sand
gives excellent
casting finish

FROM CONCEPT TO CASTING

EUROTEK

Permacure Cold box

- Rapid cure
- High tensile strength on strip
- Very low emission on castings
- Low gas evolution
- Good resin wipe properties
- Excellent bench life



FROM CONCEPT TO CASTING



From Quality Products to Quality Castings



FROM CONCEPT TO CASTING

Agents & Distributors

Eurotek has a large network of sales outlets which is continually expanding throughout Europe & elsewhere.

- **Scandinavia**
- **Germany**
- **France**
- **Holland**
- **Belgium**
- **Poland**
- **Turkey**
- **Czech Republic**
- **Egypt**
- **Jordan**
- **U.A.E**
- **Korea**
- **Ghana**
- **Tunisia**



Commitment to Quality

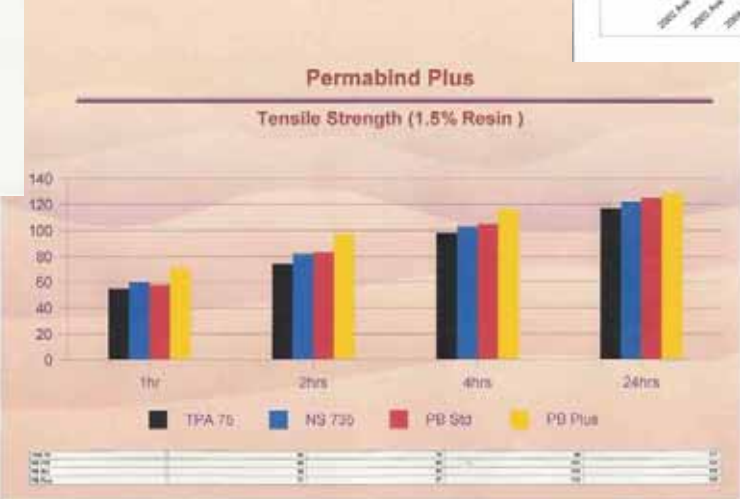

FROM CONCEPT TO CASTING

EUROTEK

Eurotek Group

Engineering Services

www.eurotek.eu.com

info@eurotek.eu.com

From concept to casting

Eurotek's Engineering Division offers a fully comprehensive range of services to cover all requirements including:

- High Speed Sand Mixers
- Sand Reclamation
- Mould Handling
- Core Making
- Process Control Technology

High Speed Sand Mixers

- **Single arm, Articulated or Mobile Versions**
- **2 – 40 tonne capacity**
- **1.5 – 8.0 metre reach available**
- **Available for all chemical processes**

EUROTEK

**Eurotek Group
Engineering Services**

High Speed Sand Mixers



www.eurotek.eu.com

info@eurotek.eu.com

Sand Reclamation

- **Low or high level versions available**
- **1 – 15 tonnes per hour capacity**
- **Integrated cooler classifiers to suit**
- **Dust & noise suppression hoods**

EUROTEK

**Eurotek Group
Engineering Services**

Sand Reclamation



www.eurotek.eu.com

info@eurotek.eu.com

Mould Handling

- **Rollover – Strip Units**
- **4, 6 & 8 Station Carousels**
- **Vibratory compaction tables**
- **Mould Manipulators**
 - pneumatic
 - hydraulic
 - electric
- **Pneumatic Conveying Systems – 1 to 20 tonnes per hour**

Mould Handling



Core Making

- **Core Shooters – 2 to 25 litre capacity**
- **New & refurbished systems**
- **Gas generators**
- **Mixing & Dosing Systems**
- **Chemical handling solutions**

Core Making



EUROTEK

EUROTEK

Process Control Technology

Main Menu

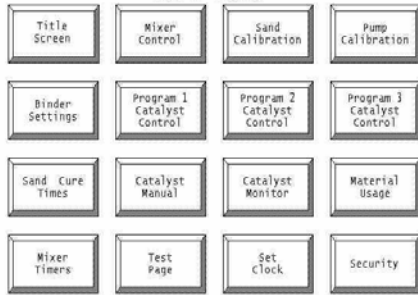

Mixer Control

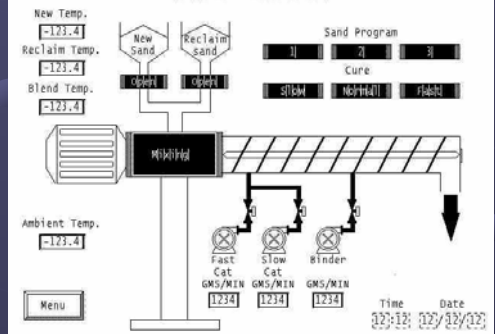

FROM CONCEPT TO CASTING

Process Control Technology

Commercial & environmental benefits including:

- Consistent Production
- Reduced Mould Scrap
- Reduced Sand Wastage
- Reduced Binder Levels
- Use of lowest S₂ containing catalysts
- Flow Control
- Data Logging
- Temperature Control
- Material Usage Monitors



FROM CONCEPT TO CASTING

EUROTEK

EUROTEK

Process Control Technology

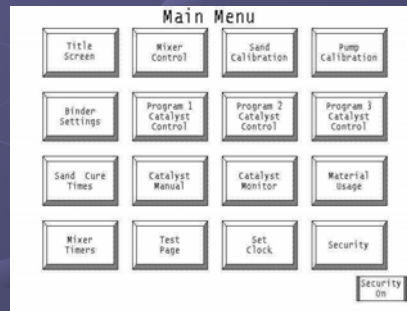
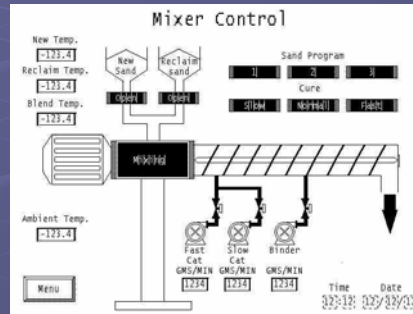

FROM CONCEPT TO CASTING

EUROTEK

EUROTEK

Contact Details:

Eurotek Foundry Products Ltd
Wistons Lane
Elland
West Yorkshire
HX5 9DT

Tel: 01422 375550

Fax: 01422 375504

Email: info@eurotek.eu.com
www.eurotek.eu.com

FROM CONCEPT TO CASTING